

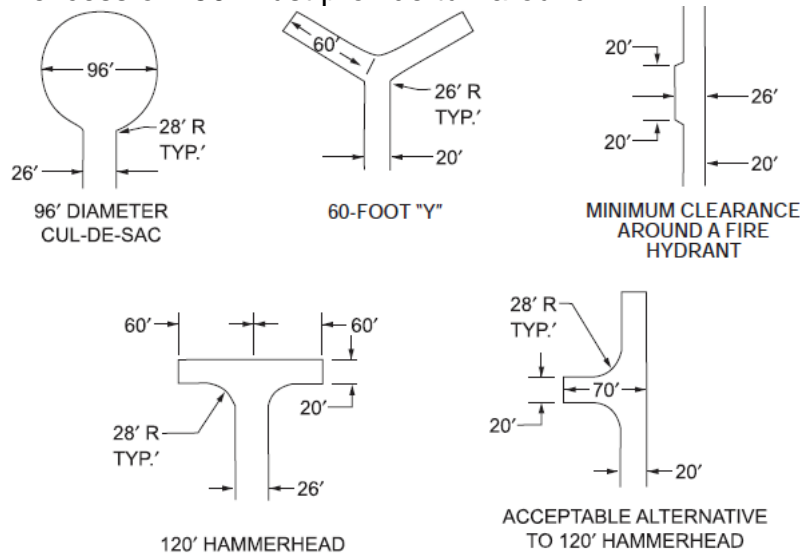

FIRE LANE REQUIERMENTS

- Fire lanes shall be measured face of curb to face of curb and not less than 24' in width.
- Minimum turning radius of 20' for buildings less than 30' in height and 30' radius for buildings more than 30' in height.
- Pavement shall be a minimum of 6" thick, 4,000 psi concrete with No 4 bars spaces 24" on centers and with a sub-grade to a density not less than 95% standard density.
- Fire lanes shall not exceed 10% in grade change with a cross slope not exceeding 5%.
- Dead end access roads in excess of 150' must provide turnaround.



For SI: 1 foot = 304.8 mm.

FIGURE D103.1
DEAD-END FIRE APPARATUS ACCESS ROAD TURNAROUND

- Fire Lane striping to be painted **"FIRE LANE NO PARKING"** the entire length of the dedicated fire lane
- Where practicable all fire lane to be painted on the curb
- Where fire lane markings are determined to be inadequate in controlling traffic the owner will be required to post fire lane signs an addition to other fire lane markings.
- When re-striping, additions to the existing fire lane are not allowed without prior approval from the fire department
- For additional Fire Lane specification contact the fire department.

